

NOTES:

1. FOR QA PURPOSES MEASURE $\phi .375$ HOLES FROM PUNCH SIDE ONLY.
2. FINISH: ZINC PLATED PER ES-P106.
3. BLANK SIZE = 21.88 INCHES.

REVISION TABLE				
REV	ER NO	DATE	ER CHANGES BY	ER APPROVAL
2	44611	4/1/10	M SALAZAR	M MACDONALD

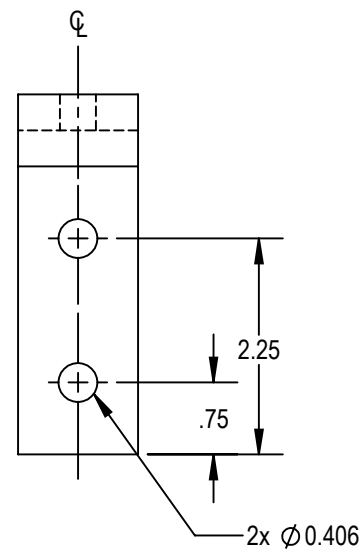
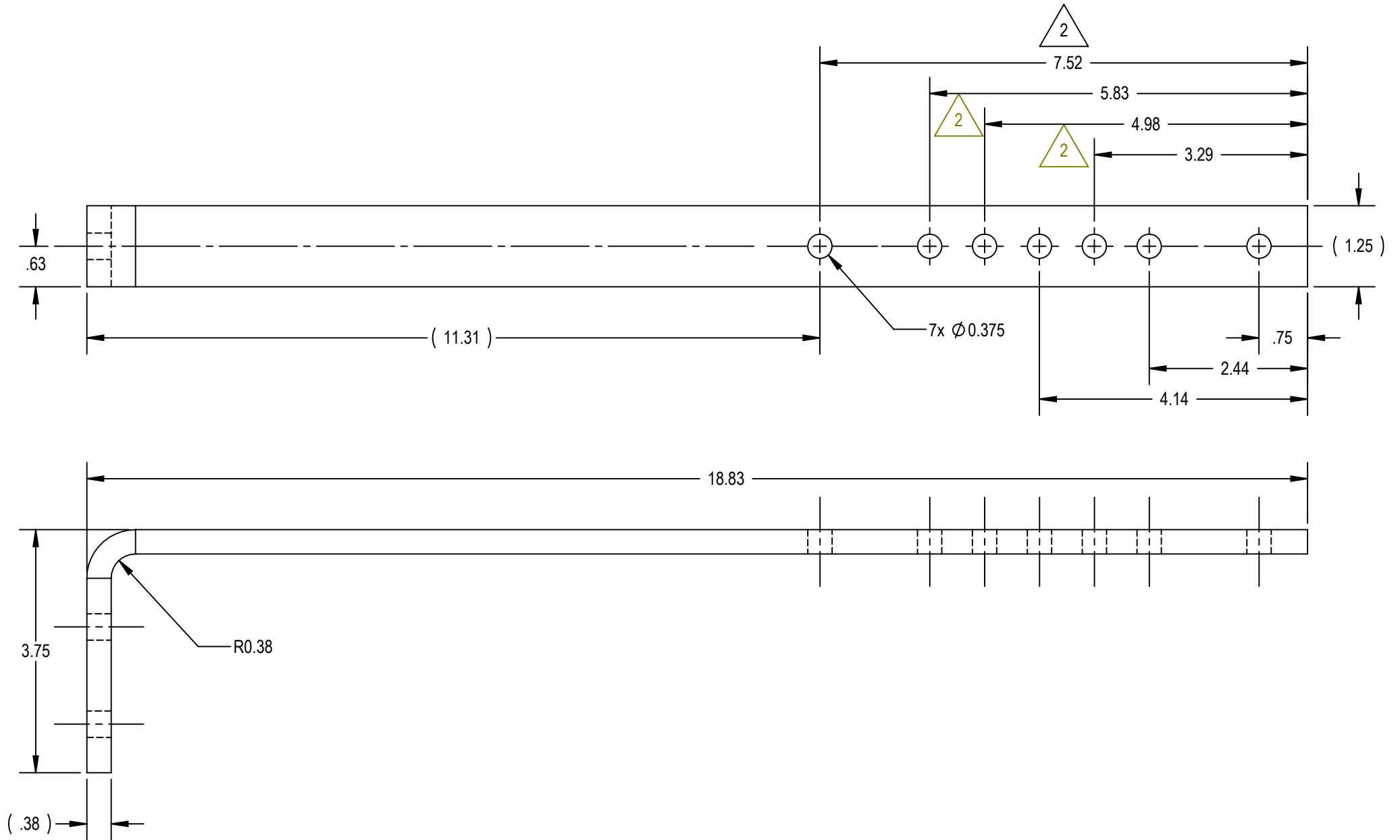

XA-28469	BAR FLAT 0.38 x 1.25	PLT STL	1.823	FT	
MATERIAL NO.	DESCRIPTION	MATL	QTY	UNIT	
DESCRIPTION: BRACKET WEB 4C 1.69 CTRS PS					
<small>PROPRIETARY AND CONFIDENTIAL</small> <small>This drawing and the information shown constitute trade secret and confidential property of Conductix-Tipton, Inc. It is subject to recall, and is loaned for use only in connection with the authorized manufacture or installation of Conductix-Tipton, Inc. products, and on the condition that it will be treated as confidential and will not be disclosed, published or reproduced in whole or in part, or permitted to be viewed or used by any other party, without specific written permission. Receipt and use of this drawing and information constitutes acceptance and agreement to the above.</small>		<small>INTERPRET GEOMETRIC TOLERANCING PER: ASME Y14.5-1994</small> <small>UNLESS OTHERWISE SPECIFIED PRIMARY UNITS ARE IN INCH POUND SECONDS SECONDARY UNITS IN MILLIMETERS KILOGRAMS SECONDS</small> <small>TOLERANCES ARE AS FOLLOWS</small> <small>DECIMAL =</small> <small>XX ± 0.1 IN (2.5 MM)</small> <small>XXX ± 0.03 IN (0.8 MM)</small> <small>XXXX ± 0.010 (0.25 MM)</small> <small>ANG. ± 1°</small> <small>FRACTION ± 1/16</small> <small>THREAD CLASS: 2</small>			
<small>DRAWN:</small> M SALAZAR 5/6/04 <small>APPR:</small> R BAUER 5/10/04	<small>CONDUCTIX</small> <small>TIPTON</small> <small>10102 F Street</small> <small>Omaha, NE 68127</small> <small>800-521-4888</small>	<small>MATERIAL NO:</small> 3095522 XA-39498 <small>REV</small> 2	<small>WEIGHT(REF): 2.79 LB</small> <small>MATL: Plain Carbon Steel</small>	<small>SHEET 1 OF 1</small>	